

B64 Pure Water pH Sensor

LECOL B64 pH sensor is designed to measure in clean water applications without strong oxidizers. Typical examples include the following:

- Boiler steam and drum water
- Steam condensate
- Steam and water recycle
- Reverse Osmosis
- Water treatment plant

LECOL B64 uses ABS for the sensor body and provides two thread sizes for the process connection, 3/4" and 1". B64 aim to measure low sample conductivity, therefore, B64 can install the solution ground to eliminate the noise from the process to get more precious reads. The sensor can be mounted directly in-line or through a dedicated flow chamber.

LECOL B6X series sensors include a large Teflon liquid junction. The large surface area of the junction reduces coating and plugging ensuring longer sensor life when compared to other designs.



Variety of glass electrode

LECOL B64 pH sensor provides four types of glass electrode for different applications:

Standard hemi-glass	Regular process water coating resistant (0-14 pH) Temperature < 80 °C
Pure water hemi-glass	Pure water application Temperature < 80 °C
Hemi-glass with PT100 temperature inside glass	Coating Resistant (0-14 pH) Hemi-glass with PT100 temperature inside glass <80 °C
Flat glass	Flat glass (0-14 pH) Temperature < 80 °C

Patented non-flowing reference

The B64 sensor patented non-flowing reference design offers a unique advantage in pure water applications.

This reference electrode is characterized by the solid elastic property, which is hydrophilic and has high water retention allowing the KCl solution to retain inside the electrode for a long time.

Therefore, it can effectively prevent the KCl from drying on the reference electrode.

Additionally, it can prevent sensor failure due to ionic contamination in the sample. This failure often occurs in high purity water or ionic solutions (deionized water, seawater, salty water, etc.). B64 sensor can provide stable performance.

USA Patent No. US 11,860,117 B2

CHINA Patent No. 202122720763.1

TAIWAN Patent No. TW M628015 U

Specifications

Measuring range:	pH: 0 ~ 14pH Temperature : 0 ~ 80 °C
Body material:	ABS
Liquid junction:	Wood notched Teflon notched
Temp. compensator:	PT100 PT1000
Operating temperature:	< 80 °C
Operating rating:	6kg/cm ² at 80 °C
Process connection:	3/4 in. NPT 1 in. NPT
Solution Ground:	SS316



LECOL

Application - steam condensate pH

Low conductivity applications ($< 10\mu\text{s}/\text{cm}$) such as steam condensate are difficult pH measurements for sensors that use a traditional salt bridge KCl reference electrode design. The low ionic strength, low conductivity, and high resistivity of pure water can lead to noisy readings and signal drift. Over time, the liquid KCl solution within the reference electrode becomes depleted as it mixes with the pure water making measurement difficult.

The non-flowing reference design of the LECOL B64 pH sensor prevents the KCl from interacting with the pure water. The result is less signal drift and longer sensor lifespan. Furthermore, since the temperature is vital to pH measurements, a temperature sensor is installed in the front of the glass electrode. This allows fast and more accurate reading of the temperature.

Temperature sensor

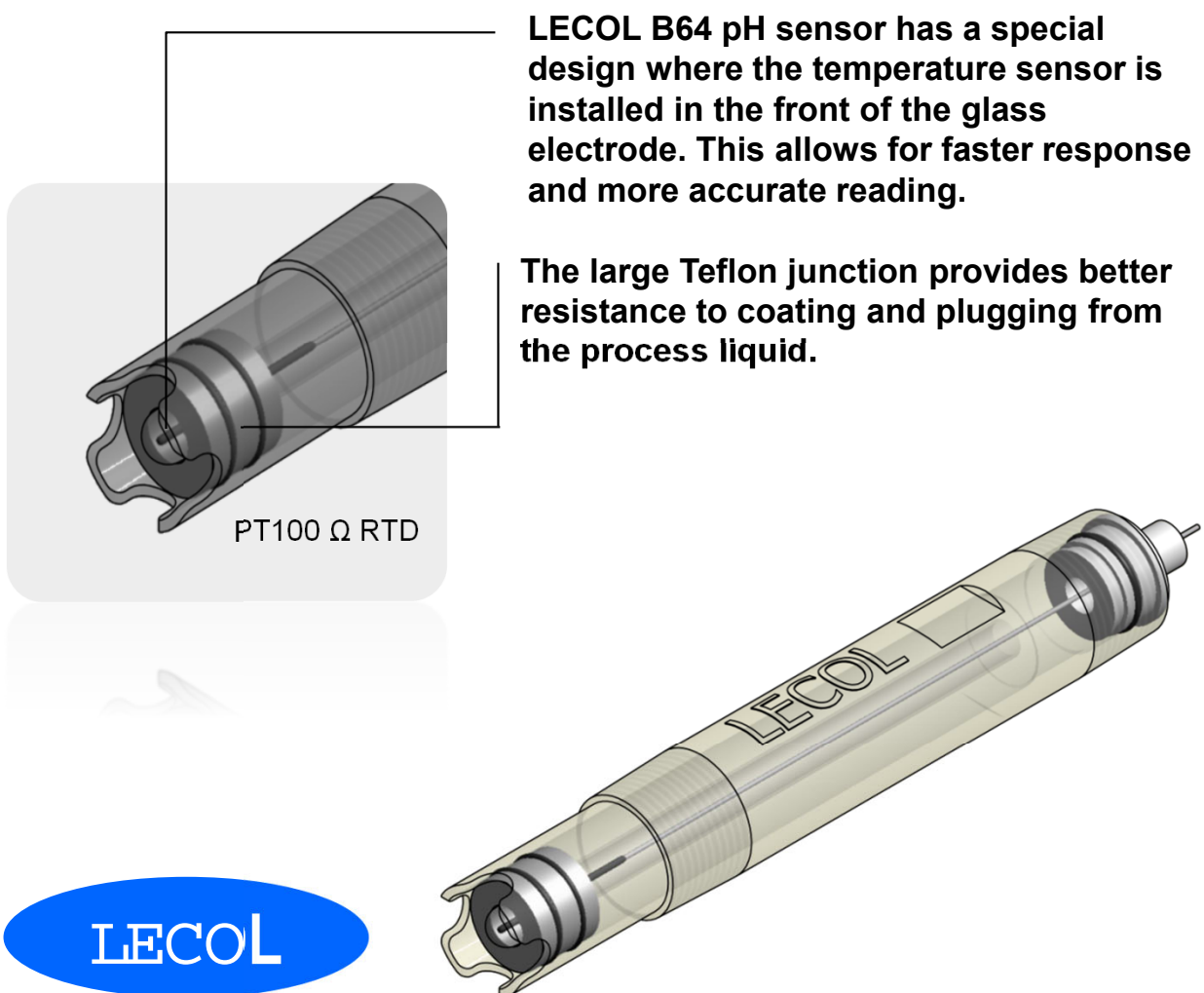

Recommended installation

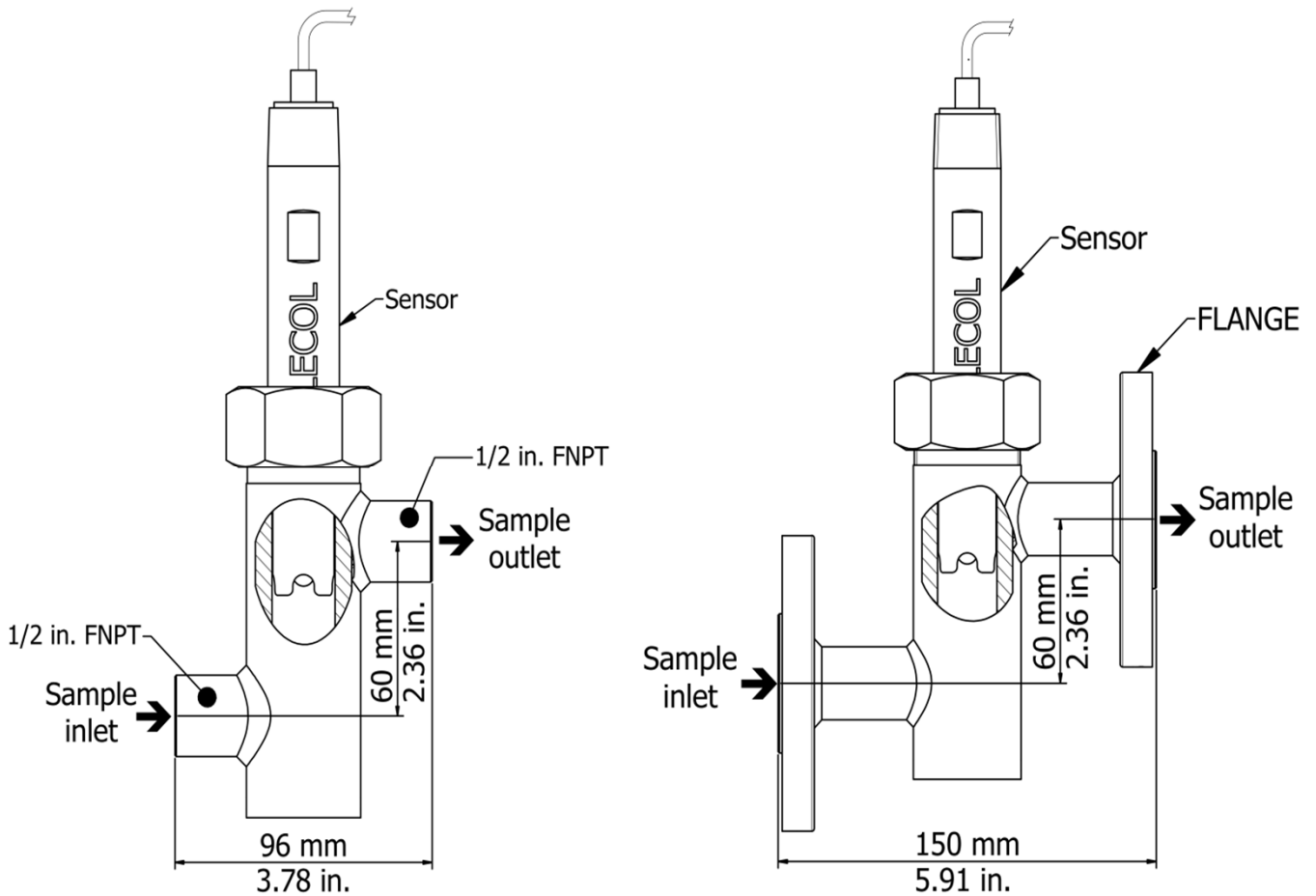

Flow chamber- 1/2 in. FNPT connection

Flow chamber- Flange connection

Note: All flow chambers include a lock nut adapter. The adapter prevent cable damage during sensor installation.

Dimensions

Process connection: 3/4 in. NPT

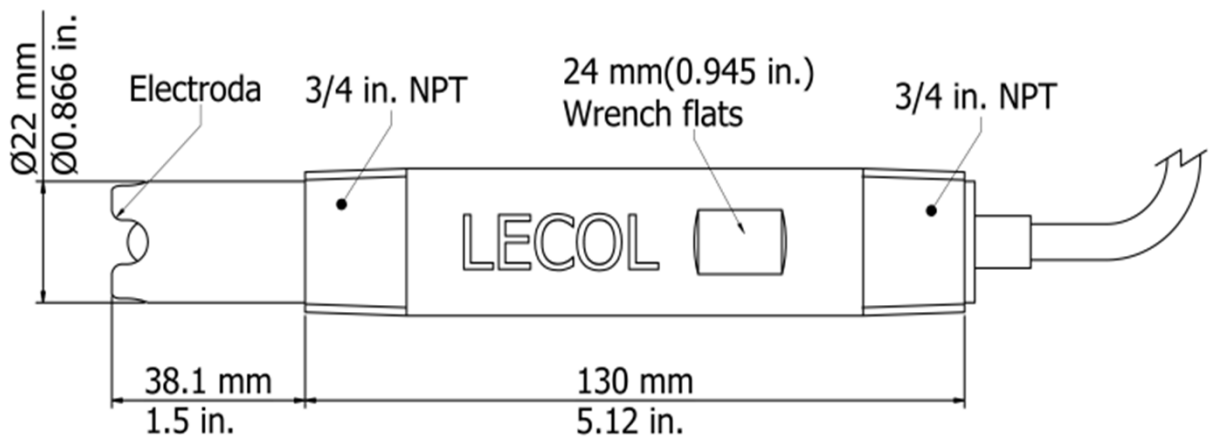

LECOL

Recommended installation

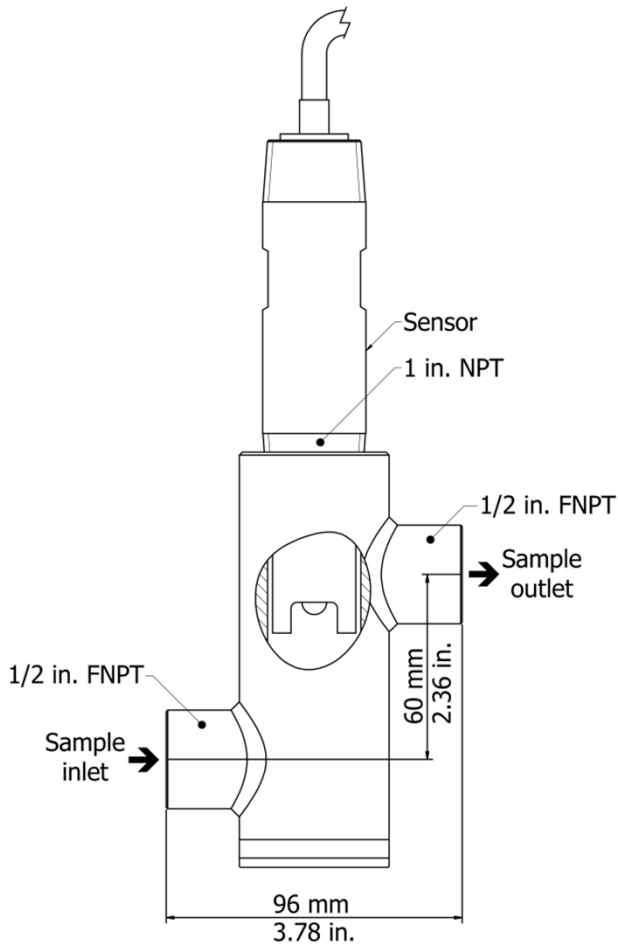

Flow chamber- 1/2 in. FNPT connection

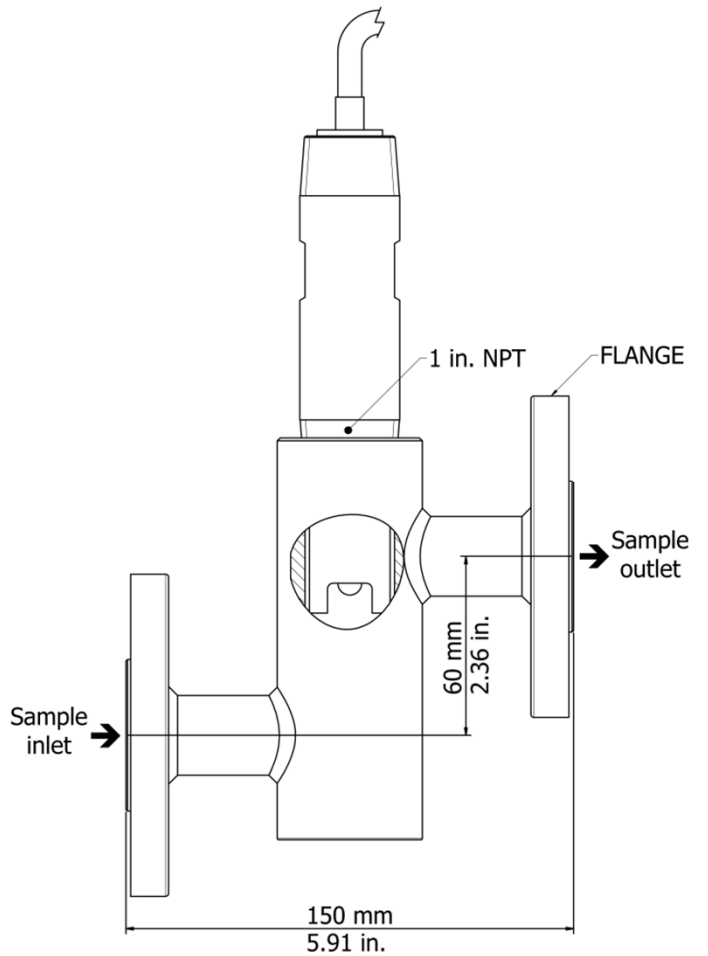

Flow chamber- Flange connection

Note: All flow chambers include a lock nut adapter. The adapter prevent cable damage during sensor installation.

Dimensions

Process connection: 1 in. NPT

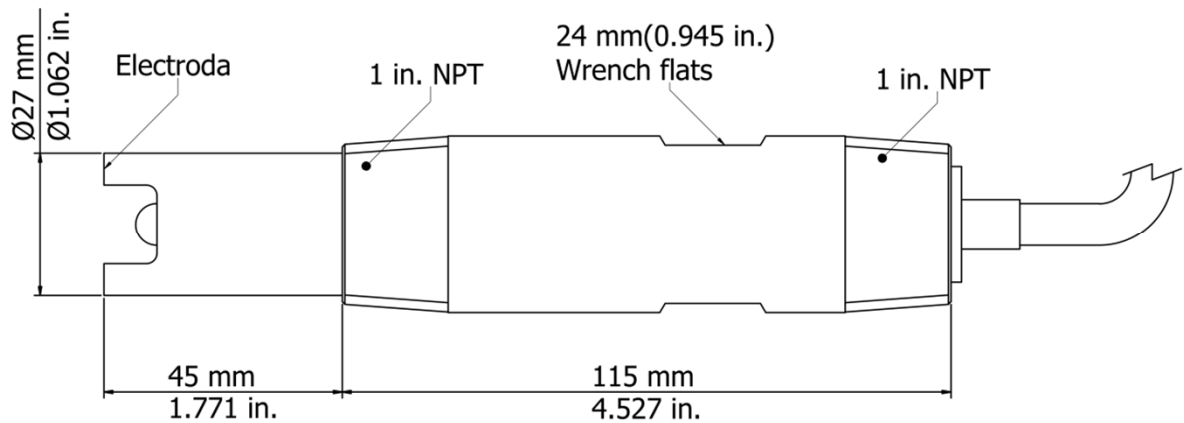

LECOL

Ordering information

Pure Water pH sensor Model: B64		(_)	(_)	(_)	(_)	(_)	(_)
A Measuring electrode		(A)					
1	pH – Coating resistant, Standard Hemi-glass (<80 °C)						
2	pH – Pure water application, Hemi-glass (<80 °C)						
4	pH – Coating resistant, Hemi-glass with PT100 temperature inside glass (<80 °C)						
5	pH – Flat glass 0-14 pH (<80 °C)						
B Temperature compensator		(B)					
0	None						
1	PT100, tinned leads						
3	PT1000, tinned leads						
C Liquid Junction		(C)					
1	Wood notched						
2	Teflon notched						
D Process Connection		(D)					
0	3/4 in. NPT						
1	1 in. NPT						
E Cable length		(E)					
0	10 cm with quick connector, connect with extension cable						
1	3M						
2	6M						
3	9M						
F Solution Ground		(F)					
0	None						
1	SS316						
G Accessory		(G)					
0	None						
	Flow Chamber 316 SS						
1	1/2 in. FNPT _____ P/N: LEFCB6-ST12						
2	1/2 in. 150#RF _____ P/N: LEFCB6-SF12						
3	3/4 in. 150#RF _____ P/N: LEFCB6-SF34						
4	1 in. 150#RF _____ P/N: LEFCB6-SF11						
8	Junction Box						
Other							
<input type="radio"/> Customized Accessory							
Other Flow Chamber size available consult factory							

*LECOL reserve the right to make technical changes or modify the contents of this document without prior notice.



Luh Cherng Enterprises co., Ltd.

No. 42, Mei-shan Rd., Niasong Dist., Kaohsiung City 83346, Taiwan

TEL : +886 7 7336377 FAX : +886 7 7336353

E-mail : sales@lecoltw.com

Website : www.lecoltw.com

